

**Producto: Prueba de inyector Common Rail para todas las marcas**

**Tema: Ámbito de aplicación y piezas**

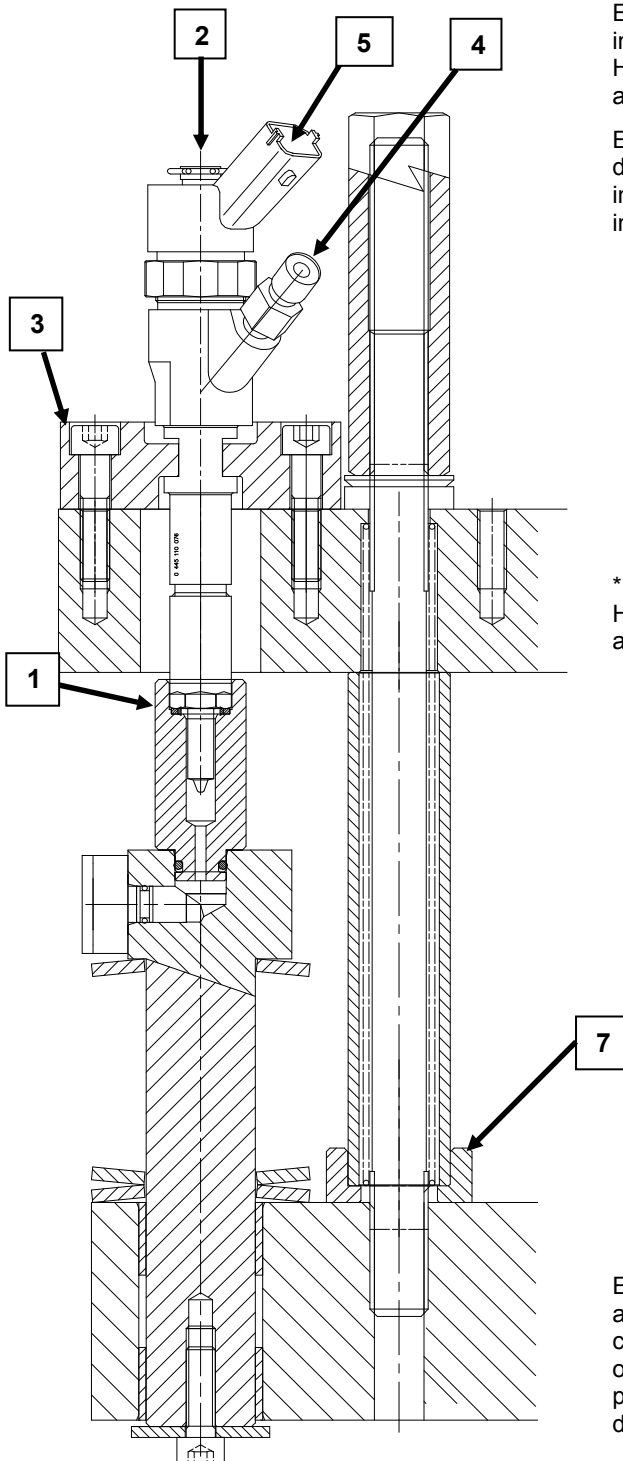

Este boletín ofrece información detallada acerca de los tipos de inyector Common Rail que pueden someterse a pruebas con el kit HK900 (en AVM2) o con el banco de pruebas CRi-PC y sobre los accesorios necesarios.

El kit HK900 incluye la unidad de control principal y el dispositivo de fijación de la base que se utilizan en todos los tipos de inyectores especificados. Es posible que en función del tipo de inyector que desee probar necesite accesorios adicionales.

El dibujo muestra un modelo típico de configuración. Estas son las piezas adicionales que no se suministran en el kit HK900:

1. Adaptador de lengüeta y precintos
2. Adaptador de reflujo (*no se muestra en el dibujo*)
3. Bloque de sujeción
4. Tubo HP (del rail al inyector) (*no se muestra en el dibujo*)
5. Cable eléctrico (*no se muestra en el dibujo*)
6. Conjunto de manguito de abastecimiento (*vea más abajo*)
7. \* Distanciador de 9kN

\* El elemento 7 (distanciador NTA5002 de 9kN) se incluye con el HK900/CRi-PC y es obligatorio para la mayor parte de aplicaciones.

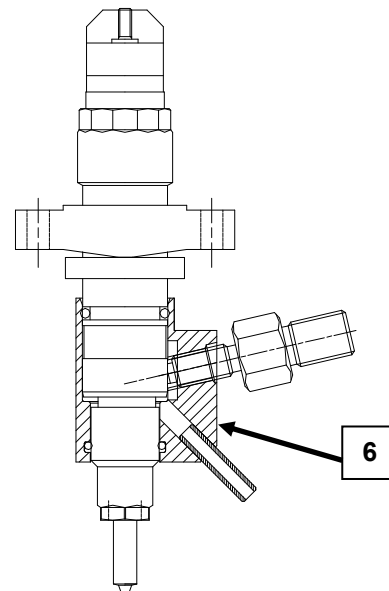

En general, el bloque de sujeción, el tubo HP y el manguito de abastecimiento serán específicos para cada número de pieza (o conjuntos de números de piezas de dimensiones idénticas). Los otros accesorios son comunes para una serie de números de piezas. Consulte las tablas de aplicaciones al dorso para determinar las piezas adecuadas para cada aplicación.

**Tabla de aplicaciones – Bosch**

Número de pieza del inyector	Aplicaciones			Adaptador de lengüeta	Adaptador de refuerzo	Bloque de sujeción	Tubo HP	Juego de cables	Conjunto de manguito de abastecimiento	necesario	NTA5002
	Fabric.	Serie	Modelo	1	2	3	4	5	6	7	
0445 110 002 0445 110 068 0445 110 119	Alfa Romeo  Fiat  Lancia	145, 146 156 166  Bravo / Brava Marea Marengo Multipla  Kappa Lybra	1.9 JTD 1.9/2.4 JTD 2.4 JTD  1.9 JTD 1.9 / 2.4 JTD 1.9 JTD 1.9 JTD  2.4 JTD 1.9/2.4 JTD	HK907 (NTA5101)	HK909 (NTA5301)	HK918 (NTA5606)	AHP5129	HK902	N/A	✓	
0445 110 009 0445 110 010 0445 110 011 0445 110 012 0445 110 024 0445 110 025 0445 110 034 0445 110 035 0445 110 055 0445 110 069 0445 110 070 0445 110 071 0445 110 072 0445 110 073 0445 110 074 0445 110 094 0445 110 095 0445 110 096 0445 110 099 0445 110 100 0445 110 104 0445 110 105 0445 110 106 0445 110 107 0445 110 108 0445 110 116 0445 110 121 0445 110 129 0445 110 156 0445 110 162 0445 110 181 0445 110 182 0445 110 189 0445 110 190 0445 110 206 0445 110 237	Mercedes Benz	Vito Sprinter C Class E Class G Class S Class V Class CLK	2.2 CDI 2.1/2.2/2.7 CDI 200/220/270 CDI 200/220/270 CDI 400 CDI 320/400 CDI 200/220 CDI 270 CDI	HK907 (NTA5101)	HK909 (NTA5301)	HK912 (NTA5601)	AHP5065	HK902	N/A	✓	
0445 110 021 0445 110 110 0445 110 146	Renault	Espace Laguna Master Megane Scenic Trafic	1.9 DCI	HK907 (NTA5101)	HK909 (NTA5301)	HK969 (NTA5631)	AHP5065	HK902	N/A	✓	
0445 110 028 0445 110 029 0445 110 030 0445 110 047 0445 110 048 0445 110 049 0445 110 130	BMW	3 Series 5 Series 7 Series X5	330d, 330xd 530d 730d, 740d 3.0 d	HK907 (NTA5101)	HK909 (NTA5301)	HK941 (NTA5619)	AHP5065	HK902	N/A	✓	
0445 110 036 0445 110 057	Citroen  Peugeot	C5 C8  406 607 807	2.2 HDi 2.2 HDi 2.2 HDi 2.2 HDi	HK907 (NTA5101)	HK909 (NTA5301)	HK937 (NTA5607)	AHP5065	HK902	N/A	✓	
0445 110 038 0445 110 063 0445 110 084 0445 110 087 0445 110 102 0445 110 141	Renault  Vauxhall / Opel	Avantime Espace Master  Movano Vivaro	2.2 DCI 2.2 DCI 2.2 / 2.5 DCI  2.5 DTI	HK907 (NTA5101)	HK909 (NTA5301)	HK971 (NTA5632)	AHP5065	HK902	N/A	✓	
0445 110 008 0445 110 044 0445 110 062 0445 110 076	Chevrolet  Citroen  Peugeot  Fiat  Lancia	Tracker  Berlingo C5 Evasion Jumper Jumpy Xantia Xsara Xsara Picasso  206 306 307 406 607 806 Boxer Expert Partner  Scudo Ulysse  Z	2.0 D  2.0 HDi 2.0 HDi 2.0 HDi 2.0/2.2 HDi 2.0 HDi 2.0 HDi 2.0 HDi 2.0 HDi  2.0 HDi 2.0 HDi 2.0 HDi 2.0 HDi 2.0/2.2 HDi 2.0 HDi 2.0 HDi  2.0 JTD 2.0 JTD  2.0 JTD	HK907 (NTA5101)	HK909 (NTA5301)	HK914 (NTA5602)	AHP5065	HK902	N/A	✓	

**Tabla de aplicaciones – Bosch**

Número de pieza del inyector	Aplicaciones			Adaptador de lengüeta	Adaptador de refiljo	Bloque de sujeción	Tubo HP	Juego de cables	Conjunto de manguito de abastecimiento	¿Es necesario NTA5002?	
	Fabric.	Serie	Modelo	1	2	3	4	5	6	7	
0445 110 059	Chrysler	Voyager	2.5 ltr	HK907 (NTA5101)	HK909 (NTA5301)	HK986 (NTA5641)	AHP5065	HK902	N/A	✓	
0445 110 064 0445 110 101 0445 110 126	Hyundai	Accent Elantra Matrix Santa Fe Tussan Trajet	1.5 CRDi 2.0 CRDi 1.5 CRDi 2.0 CRDi 2.0 CRDi 2.0 CRDi	HK907 (NTA5101)	HK909 (NTA5301)	HK939 (NTA5618)	AHP5065	HK902	N/A	✓	
	Kia	X-Trax Sportage	2.0 CRDi								
0445 110 075 0445 110 135	Citroen	C3 Xsara	1.4 HDI 1.4 HDI	HK907 (NTA5101)	HK909 (NTA5301)	HK947 (NTA5623)	AHP5129	HK902	N/A	✓	
	Peugeot	206 307	1.4 HDI 1.4 HDI								
0445 110 077 0445 110 078	Volvo	S60 S80 V70 XC70 XC90	2.4 D 2.4 D, D5 2.4 D, D5 2.4 D, D5 D5	HK907 (NTA5101)	HK909 (NTA5301)	HK978 (NTA5633)	AHP5065	HK902	N/A	✓	
0445 110 083 0445 110 183	Fiat	Albea Doblo Idea Palio Panda Punto Strada	1.3 JTD	HK907 (NTA5101)	HK909 (NTA5301)	HK980 (NTA5634)	AHP5065	HK902	N/A	✓	
	Lancia	Musa Ypsilon	1.3 JTD								
	Vauxhall / Opel	Agila Astra Combo Corsa Meriva Tigra	1.3 CDTI								
0445 110 085 0445 110 215	Toyota			HK907 (NTA5101)	HK909 (NTA5301)	HK982 (NTA5636)	AHP5065	HK902	N/A	✓	
0445 110 086 0445 110 092 0445 110 185 0445 110 186	Kia	Sorento	2.5 CRDi	HK907 (NTA5101)	HK909 (NTA5301)	HK942 (NTA5620)	AHP5065	HK902	N/A	✓	
	Hyundai	Porter	2.5 CRDi								
0445 110 118 0445 110 174	GM / Opel	Astra Combo Corsa Meriva	1.7 CDTI	HK907 (NTA5101)	HK909 (NTA5301)	AVM2-PC: HK943 (NTA5621) CRI-PC: HK1018 (NTA5660)	AHP5129	HK902	N/A	✓	
0445 110 080 0445 110 131	BMW	3 Series 3 Series 5 Series 7 Series X5	320 Cd / d / td 330 Cd / d / xd 530 d 730 d 3.0 d	HK907 (NTA5101)	HK909 (NTA5301)	HK988 (NTA5642)	AHP5065	HK902	N/A	✓	
0445 110 159	Vauxhall / Opel / SAAB	Astra Signum Vectra Zafira 9-3 9440	1.9 CDTI	HK907 (NTA5101)	HK909 (NTA5301)	HK990 (NTA5643)	AHP5065	HK902	N/A	✓	
0445 110 188	Citroen	C4, C5, 1.6HDI, Xsara, Picasso		HK907 (NTA5101)	HK909 (NTA5301)	HK1010 (NTA5658)	AHP5065	HK902	N/A	✓	
	Ford	Focus, C Max, Focus 2									
	Peugeot	206, 307, 407									
	Volvo	C30, S40, V50									
0445 110 217	Jeep	Liberty		HK907 (NTA5101)	HK909 (NTA5301)	HK1089 (NTA5704)	AHP5065	HK902	N/A	✓	
0445 110 273	Fiat IVECO	Ducato Daily	2.3 ltr 2.3 ltr	HK908 (NTA5102)	HK909 (NTA5301)	HK973 (NTA5638)	AHP5065	HK902	N/A	✓	
0445 115 007				KNA	KNA	KNA	KNA	KNA	N/A	✓	
				AVM2 & CRI							
				IFT-70	N/A	N/A	N/A	N/A	HK1118	N/A	N/A
0445 115 026 0445 115 027 0445 115 059 0445 115 060				HK907 (NTA5101)	N/A	HK1060 (NTA5685)	AHP5066	HK1090	N/A	✓	
0445 115 063 0445 115 064	Mercedes		OM642								
0445 115 053 0445 115 054	Audi	A4 A6	2.7L	HK907 (NTA5101)	N/A	HK1068 (NTA5690) + HK1057 (NTA5682)	AHP5066	HK1090	N/A	✓	
0445 120 002	Fiat IVECO Renault	Ducato Daily Mascott	2.8 JTD 2.8 litre 2.8 litre	HK908 (NTA5102)	HK909 (NTA5301)	HK922 (NTA5605)	AHP5065	HK902	N/A	✓	

## Tabla de aplicaciones – Bosch

0445 120 003 0445 120 004 0445 120 019 0445 120 020	Renault	Premium Kerax	11.1 litre	<b>HK921</b> (NTA5103)	<b>N/A</b>	<b>HK934</b> (NTA5617)	<b>AHP5130</b>	<b>HK903</b>	<b>HK936</b> (NTA5402, NTA5501)	✓
0445 120 007 0445 120 018 0445 120 028	Cummins applications			<b>HK907</b> (NTA5101)	<b>N/A</b>	<b>HK926</b> (NTA5603)	<b>AHP5130</b>	<b>HK903</b>	<b>HK928</b> (NTA5401, NTA5501)	✓
0445 120 008	GM	Sierra	Duramax 2500HD Duramax 3500	<b>HK921</b> (NTA5103)	<b>HK910</b> (NTA5302)	<b>HK924</b> (NTA5604)	<b>AHP5066</b>	<b>HK903</b>	<b>N/A</b>	✓
	Chevrolet	Silverado	Duramax 2500HD Duramax 3500							
0445 120 011	Fiat IVECO	Ducato 11/15/18 Daily 29/35	2.3 JTD 2.3 ltr	<b>HK908</b> (NTA5102)	<b>HK909</b> (NTA5301)	<b>HK973</b> (NTA5638)	<b>AHP5065</b>	<b>HK902</b>	<b>N/A</b>	✓
0445 120 012 0445 120 013	Renault	Midlum Premium	4.0, 6.2 ltr 6.2 ltr	<b>HK998</b> (NTA5105)	<b>N/A</b>	<b>HK975</b> (NTA5639) <b>+ HK976</b> (NTA5640)	<b>AHP5066</b>	<b>HK903</b>	<b>N/A</b>	✓
0445 120 030	MAN	TGA D2066LF	7.5 ltr	<b>HK907</b> (NTA5101)	<b>N/A</b>	<b>HK991</b> (NTA5648)	<b>AHP5130</b>	<b>HK903</b>	<b>HK992</b> (NTA5405, NTA5501)	✓
0445 120 041	MAN			<b>HK907</b> (NTA5101)	<b>N/A</b>	<b>HK1052</b> (NTA5678)	<b>AHP5130</b>	<b>HK903</b>	<b>HK992</b> (NTA5405, NTA5501)	✓
0445 120 045 0445 120 098	MAN	TGA D0836LF TGAL D0834LF TGAM 0836LF	12 ltr, 4.6 ltr, 6.9 ltr	<b>HK907</b> (NTA5101)	<b>N/A</b>	<b>HK1012</b> (NTA5654)	<b>AHP5130</b>	<b>HK903</b>	<b>HK1013</b> (NTA5406, NTA5501)	✓
0445 120 050 0445 120 059 0445 120 071 0445 120 161 0445 120 184 0445 120 185	Cummins applications			<b>HK907</b> (NTA5101)	<b>N/A</b>	<b>HK1014</b> (NTA5661)	<b>AHP5130</b>	<b>HK903</b>	<b>HK928</b> (NTA5401)	✓
0445 120 006	MAN			<b>HK921</b> (NTA5103)	<b>N/A</b>	<b>HK1019</b> (NTA5664)	<b>AHP5130</b>	<b>HK903</b>	<b>HK1020</b> (NTA5408)	✓
0445 120 044	MAN		TGA 18.480 – 12.8 L TGA18530F – 12.8 L TGA24.480 – 12.8 L TGA 56.530 – 12.8 L	<b>HK907</b> (NTA5101)	<b>N/A</b>	<b>HK1012</b> (NTA5654)	<b>AHP5130</b>	<b>HK903</b>	<b>HK1016</b> (NTA5407, NTA5501)	✓
<b>0445 120 042</b>	Chevrolet GMC	3500 Top kick Kodiak 2500HD Hummer H1	Duramax 6.6 ltr	<b>HK907</b> (NTA5101)	<b>HK909</b> (NTA5301)	<b>HK1024</b> (NTA5668)	<b>AHP5066</b>	<b>HK902</b>	<b>N/A</b>	✓
0445 120 065 0445 120 066 0445 120 067	Deutz	04290986 04290987	KHD0429 0986 HKD0429 0987 TCD4120122V (US)	<b>HK907</b> (NTA5101)	<b>HK1047</b> (NTA5412)	<b>HK1046</b> (NTA5674)	<b>AHP5066</b>	<b>HK903</b>	<b>N/A</b>	✓
0445 120 064 0445 120 136 0445 120 137	Deutz Renault Volvo	KDH04290 2825 Midlum, Premium	4.8, 7.2 ltr	<b>HK907</b> (NTA5101)	<b>N/A</b>	<b>HK1044</b> (NTA5675)	<b>AHP5066</b>	<b>HK903</b>	<b>HK1045</b> (NTA5413, NTA5501)	✓
0445 120 029 0445 120 125	Komatsu			<b>HK907</b> (NTA5101)	<b>N/A</b>	<b>HK1040</b> (NTA5672)	<b>AHP5130</b>	<b>HK903</b>	<b>HK1041</b> (NTA5410, NTA5505)	✓
0445 120 035 0445 120 125 0445 120 112	Cummins	4940439 4940170								

**Tabla de aplicaciones – Delphi**

Número de pieza del inyector	Aplicaciones			Adaptador de lengüeta	Adaptador de reflujo	Bloque de sujeción	Tubo HP	Juego de cables	Conjunto de manguito de abastecimiento	¿Es necesario NTA5002?	
	Fabric.	Serie	Modelo	1	2	3	4	5	6	7	
EJBR01001A EJBR01001Z	Suzuki Citroen	Liana C3	1.4 Ddis 1.4 HDI	HK907 (NTA5101)	HK911 (NTA5303)	HK916 (NTA5610) + HK933 (NTA5614)	<p style="text-align: center;"><b>La Solución Oficial requiere HK917 (1/4: AHP5009 2/3: AHP5010) o AHP5066 para todas las marcas</b></p>	HK904	N/A	✓	
EJBR00801Z EJBR01101Z EJBR01301Z EJBR01302Z EJBR01601Z EJBR02001Z EJBR02201Z	Ford	Focus Transit Connect Tourneo Connect	1.8 TDCi 1.8 TDCi 1.8 TDCi	HK907 (NTA5101)	N/A	HK916 (NTA5610) + HK930 (NTA5611)		HK904	N/A	✓	
EJBR01201Z EJBR01401Z EJBR01501Z EJBR01701Z EJBR01801A EJBR01801Z EJBR02101Z EJBR02701Z EJBR03101D EJBR04001D EJBR04101D EJBR05101D EJBR05102D EJBR05201D EJBR05601D	Renault Nissan Suzuki	Clio Kangoo Megane Scenic Modus Almera Kubistar Micra Jimny	1.5 dCi 1.5 dCi 1.5 dCi 1.5 dCi 1.5 dCi 1.5 dCi 1.5 dCi 1.5 Ddis	HK907 (NTA5101)	N/A	HK916 (NTA5610)		HK904	N/A	✓	
EJBR05301D EJBR06101D	Yuchai		2.5 ltr 2.6 ltr								
EJBR00901Z EJBR01901Z EJBR02301Z EJBR02401Z EJBR02501Z EJBR02801D EJBR02901D EJBR03001D EJBR03201D EJBR03601D EJBR03701D	Kia	Carnival Pregio Bongo Frontier	2.9 HPDi 2.9 HPDi 2.9 HPDi 2.9 HPDi	HK907 (NTA5101)	N/A	HK916 (NTA5610) + HK931 (NTA5612)		HK904	N/A	✓	
EJBR03901D EJBR03902D EJBR05501D	Hyundai Kia		2.9								
EJBR03301D EJBR03501D	JMC TATA		2.8 3.0								
EJBR02601Z EJBR03401Z EJBR04601Z EJBR04701Z	Ssangyong	Rodius Rexton	D27DT D20DT D27DT D20DT	HK907 (NTA5101)	N/A	HK916 (NTA5610) + HK932 (NTA5613)		HK904	N/A	✓	
EJBR04301D EJBR04901D EJBR05701D	TATA		1.4L 2.2L								
EJBR04401Z EJBR04501Z EJBR04401D EJBR04501D	Ssangyong										
EJBR03801D EJBR06001D	PSA			HK907 (NTA5101)	HK911 (NTA5303)	HK1001 (NTA5650)		HK904	N/A	✓	
EJBR04201D	Daimler Chrysler			HK907 (NTA5101)	HK911 (NTA5303)	HK916 (NTA5610) + HK1004 (NTA5651)		HK904	N/A	✓	
EJBR05001D	JCB		4.4L	HK907 (NTA5101)	HK911 (NTA5303)	HK987 (NTA5644)		HK904	N/A	✓	
EJBR06201D				HK907 (NTA5101)	HK911 (NTA5303)	HK916 (NTA5610) + HK1005 (NTA5655)		HK904	N/A	✓	
EJDR00001Z EJDR00002Z EJDR00101Z EJDR00201Z EJDR00202Z EJDR00301Z EJDR00401Z EJDR00402Z EJDR00403Z EJDR01001D EJDR01101D	Ford	Mondeo Transit	2.0 TDCi 2.0 TDCi	HK907 (NTA5101)	HK911 (NTA5303)	HK920 (NTA5608)		HK904	N/A	✗	

**Tabla de aplicaciones – Delphi**

EJDR00501Z EJDR00502Z EJDR00503Z EJDR00504Z EJDR00601Z EJDR00701D EJDR00801D	Ford  Jaguar	Mondeo  X400	2.0 TDCi  2.0 TDCi	HK907 (NTA5101)	HK911 (NTA5303)	HK920 (NTA5608) + HK929 (NTA5609)		HK904	N/A	x
28229876	JCB			HK907 (NTA5101)	HK1120 (NTA5308)	HK1114 (NTA5724)	AHP5066  para todas las marcas	HK904	N/A	✓
28231014	GreatWall		4D20	HK907 (NTA5101)	N/A	HK1115 (NTA5725)		HK904	N/A	✓
28269978 28320793	Daedong			HK907 (NTA5101)	N/A	HK1116 (NTA5726)		HK904	N/A	✓
EMBR00101D EMBR00101DP	PSA			HK907 (NTA5101)	HK1120 (NTA5308)	HK1091 (NTA5705) + HK1004 (NTA5651)		HK904	N/A	✓
28234058	Doosan			HK907 (NTA5101)	N/A	HK1098 (NTA5709) + HK1099 (NTA5710)	AHP5130  para todas las marcas	HK904	N/A	✓
EMBR00001D EMBR00002D 28334532 28271551 28230891	Daimler Chrysler		OM651	HK907 (NTA5101)	HK1120 (NTA5308)	HK1098 (NTA5709) + HK1100 (NTA5711) + HK1101 (NTA5713)		HK1093	N/A	✓
EMBR00201D EMBR00202D EMBR00203D 28235143	Kia HMC			HK907 (NTA5101)	N/A	HK1098 (NTA5709) + HK1102 (NTA5714) + HK1103 (NTA5715)		HK1093	N/A	✓
28239766 28264951	GMDAT		Z22D	HK907 (NTA5101)	N/A	HK1098 (NTA5709) + HK1104 (NTA5716) + HK1105 (NTA5717)		HK1093	N/A	✓
28239789 28264952	GMDAT		Z20D							
28231462	VW			HK907 (NTA5101)	HK1120 (NTA5308)	HK1098 (NTA5709) + HK1106 (NTA5718) + HK1107 (NTA5719)		HK1093	N/A	✓
EMBR00301D	SsangYong			HK907 (NTA5101)	N/A	HK1098 (NTA5709) + HK1108 (NTA5720) + HK1103 (NTA5715)		HK1093	N/A	✓
28229873	HMC A Engine (WGT)			HK907 (NTA5101)	N/A	HK1098 (NTA5709) + HK1110 (NTA5722) + HK1105 (NTA5717)		HK1093	N/A	✓
28236381	HMC A Engine (VGT)									

**Tabla de aplicaciones – Denso**

Número de pieza del inyector	Aplicaciones			Adaptador de lengüeta	Adaptador de refujo	Bloque de sujeción	Tubo HP	Juego de cables	Conjunto de manguito de abastecimiento	¿Es necesario NTA5002?
	Fabric	Ref	Modelo	1	2	3	4	5	6	7
095000-014x				HK921 (NTA5103)	HK1007 (NTA5305)	HK1008 (NTA5656)	AHP5066	HK963	N/A	✓
095000-057x	Toyota	23670-27030	Avensis Avensis Verso Previa RAV4	HK907 (NTA5101)	HK910 (NTA5302)	HK997 (NTA5637) + HK956 (NTA5626) + HK932 (NTA5613)	AHP5065	HK905	N/A	✓
095000-064x	Toyota	23670-29025	Corolla							
095000-075x	Toyota	23670-39025	Land Cruiser							
095000-094x	Toyota	23670-39035	4Runner Dyna Hiace Hilux Tiger 2.5l							
095000-542x	Toyota	23670-09030	Avensis Avensis Verso Corolla Corolla Verso							
095000-544x	Toyota		Hiace							
095000-592x										
095000-738x										
095000-739x										
095000-754x										
095000-775x										
095000-776x										
095000-778x										
095000-779x	Toyota	23670-29045	Avensis Corolla							
095000-560x	Mitsubishi	1465A041	L200							
095000-566x										
095000-574x	Toyota		Land Cruiser							
095000-772x										
095000-773x										
095000-589x	Toyota	23670-39135	Land Cruiser							
095000-593x	Toyota	23670-09060 23670-0L010	Hilux Vigo 2.5l							
095000-676x	Toyota		Hilux							
095000-703x										
095000-721x	Toyota		Avensis							
095000-722x										
095000-755x										
095000-758x										
095000-781x	Toyota		Dyna							
095000-782x										
095000-783x										
095000-784x										
095000-588x	Toyota									
095000-805x										
095000-806x										
095000-816x										
095000-822x										
095000-829x										
095000-838x										
095000-839x										
095000-849x										
095000-850x										
095000-856x										
095000-074x				Toyota	23670-39015	Land Cruiser				
095000-095x	Toyota	23670-39045	Dyna							
095000-611x	Toyota	23670-09130	Avensis							
095000-623x	Toyota	23670-09140	Corolla Verso RAV4							
095000-760x	Toyota		Avensis							
095000-761x										
095000-766x										
095000-767x										
095000-768x										
095000-769x										
095000-770x	Toyota		Land Cruiser							
095000-771x										
095000-763x	Toyota		RAV4							
095000-764x										
095000-051x	Nissan	16600-8H80x 16600-AU600 16600-AW40x 16600-BN80x 16600-EB30x 16600-ES60x 16600-MB40x 16600-EC00x	Almeria Cabstar Pathfinder Primera Navara X-Trail							
095000-088x										
095000-513x										
095000-518x										
095000-565x										
095000-602x										
095000-624x										
095000-625x										

## Tabla de aplicaciones – Denso

095000-576x	Mitsubishi	1465A054	Pajero Montero	HK907 (NTA5101)	HK910 (NTA5302)	HK997 (NTA5637) + HK956 (NTA5626) + HK1000 (NTA5649)	AHP5065	HK905	N/A	✓
095000-056x	Komatsu	62181-13100 62181-13101		HK921 (NTA5103)	HK962 (NTA5403)	HK964 (NTA5629)	AHP5130	HK963	N/A	✓
095000-076x	Isuzu		S6D1	HK907 (NTA5101)	HK1007 (NTA5305)	HK1061 (NTA5686)	AHP5066	HK905	N/A	✓
095000-080x	Komatsu	61561-13100		HK921 (NTA5103)	HK962 (NTA5403)	HK960 (NTA5628)	AHP5066	HK963	N/A	✓
095000-121x	Komatsu			HK984 (NTA5104)	HK962 (NTA5403)	HK1055 (NTA5680)	AHP5066	HK963	N/A	✓
095000-505x 095000-548x	John Deere	RE507860 RE520240	Tractor (6045 engine)	HK907 (NTA5101)	N/A	HK966 (NTA5630)	AHP5130	HK963	HK968 (NTA5404, NTA5502)	✓
095000-512x	Toyota	23670-0G010	Avensis Corolla RAV4	HK907 (NTA5101)	HK910 (NTA5302)	HK910 (NTA5302)	AHP5065	HK905	N/A	✓
095000-551x 095000-627x 095000-630x	Isuzu			HK984 (NTA5104)	HK1007 (NTA5305)	HK1056 (NTA5681)	AHP5130	HK963	N/A	✓
095000-670x 095000-801x	CNHTC			HK984 (NTA5104)	HK1007 (NTA5305)	HK1008 (NTA5656) + HK1057 (NTA5682)	AHP5066	HK963	N/A	✓
095000-679x				HK984 (NTA5104)	HK910 (NTA5302)	HK1058 (NTA5683)	AHP5065	HK905	N/A	✓
095000-698x 095000-699x	Isuzu	98011604 98011605	2.5 ltr 3.0 ltr	HK907 (NTA5101)	HK1006 (NTA5307)	HK1002 (NTA5652) + HK1003 (NTA5653)	AHP5066	HK905	N/A	✓
095000-508x	Vauxhall / Opel	97313861	Corsa Combo Meriva	HK907 (NTA5101)	HK1006 (NTA5307)	HK1097 (NTA5712)	AHP5129	HK905	N/A	✓
095000-613x	Isuzu Opel									
095000-521x				HK984 (NTA5104)	HK994 (NTA5304)	HK1027 (NTA5676)	AHP5066	HK963	N/A	✓
095000-534x 095000-535x 095000-536x 095000-547x 095000-638x 095000-639x	Isuzu (Opel)		Corsa Combo Meriva	HK921 <sup>[1]</sup> (NTA5103)	HK1007 (NTA5305)	HK1008 (NTA5656)	AHP5130	HK963	N/A	✓
095000-580x 095000-581x 095000-662x 095000-706x	Citroen Fiat Ford Land Rover Peugeot	6C1Q-9K546-AC 6C1Q-9K546-BB  6C1Q-9K546-BC	Jumper 2.2ltr Ducato 2.2ltr Transit 2.2, 2.4ltr Defender 2.4ltr Boxer 2.2, 2.4ltr	HK907 (NTA5101)	HK1006 (NTA5307)	HK997 (NTA5637) + HK956 (NTA5626) + HK1009 (NTA5657)	AHP5065	HK905	N/A	✓
095000-578x	Mazda	RF7J13H50	3, 5, 6	HK907 (NTA5101)	HK910 (NTA5302)	HK997 (NTA5637) + HK956 (NTA5626) + HK1011 (NTA5659)	AHP5130	HK905	N/A	✓
095000-539x 095000-599x 095000-635x 095000-692x	Hino Nissan Toyota			HK984 (NTA5104)	HK910 (NTA5302)	HK993 (NTA5645)	AHP5130	HK963	N/A	✓
095000-528x 095000-659x 095000-660x 095000-675x 095000-681x 095000-809x	Hino Nissan Toyota			HK984 (NTA5104)	HK994 (NTA5304)	HK993 (NTA5645)	AHP5066	HK963	N/A	✓
095000-503x	Mazda		MPV 6	HK907 (NTA5101)	HK1006 (NTA5307)	HK1023 (NTA5666, NTA5667) + HK1117 (NTA5727)	AHP5130	HK905	N/A	✓
095000-810x				HK984 (NTA5104)	HK994 (NTA5304)	HK1059 (NTA5684)	AHP5066	HK905	N/A	✓

<sup>[1]</sup> Solo encajarán los kits/piezas comprados después de marzo de 2009 (diseño modificado para adaptarlo a esta aplicación).

**NOTA:** Tubos HP para la Solución Oficial Denso por determinar.

**Tabla de aplicaciones – CAT/ Perkins**

Número de pieza del inyector	Aplicaciones			Adaptador de lengüeta	Adaptador de reflujo	Bloque de sujeción	Tubo HP	Juego de cables	Conjunto de manguito de abastecimiento	¿Es necesario NTA5002?
	Fabric	Ref	Modelo	1	2	3	4	5	6	7
2S0012401325/ 2645A718 2S00491407FB / 2645A749	Perkins		100VK, NH1, NJ1, 1104D engines	HK907 (NTA5101)	N/A	HK1042 (NTA5673)	AHP5066	HK963	HK1043 (NTA5411)	✓

**Tabla de aplicaciones – Siemens**

Número de pieza del inyector	Aplicaciones			Adaptador de lengüeta	Adaptador de reflujó	Bloque de sujeción	Tubo HP	Juego de cables	Conjunto de manguito de abastecimiento	¿Es necesario NTA5002?	
	Fabric	Ref	Modelo	1	2	3	4	5	6	7	
5WS40000-Z	PSA	1980 F0 96 521 736 80	DW10TD 2.0ltr	HK907 (NTA5101)	HK909 (NTA5301)	HK945 (NTA5622)	AHP5065	HK906	N/A	✓	
5WS40148-Z	Ford	2S6Q-9F593-AB 2S6Q-9F593-AC	1.4 Litre Euro 3	HK907 (NTA5101)	HK909 (NTA5301)	HK947 (NTA5623)	AHP5065	HK906	N/A	✓	
	PSA	96 553 048 80 1980 E7									
5WS40149-Z	Ford	2S6Q-9F593-BC	1.4 Litre Euro 4	HK907 (NTA5101)	HK909 (NTA5301)	HK949 (NTA5624)	AHP5065	HK906	N/A	✓	
	PSA	96 545 509 80 1980 J1									
5WS40156-4Z	Ford	3M5Q 9F593 DB	DW10B Class 4	HK907 (NTA5101)	HK909 (NTA5301)	HK949 (NTA5624)	AHP5065	HK906	N/A	✓	
	PSA	1980 J5 96 571 445 80									
	Volvo	8603565									
5WS40156-Z	Ford	3M5Q 9F593 EB	DW10B Class 5	HK907 (NTA5101)	HK909 (NTA5301)	HK949 (NTA5624)	AHP5065	HK906	N/A	✓	
	PSA	1980 J5 96 571 447 80									
	Volvo	8603564									
5WS40057 (A2C59511315)	Ford Jaguar PSA	Lion V6	2.7i Litre Euro 3/4	HK907 (NTA5101)	HK909 (NTA5301)	HK989 (NTA5635)	AHP5065	HK906	N/A	✓	
5WS40103 (A2C59511316)	Ford	5U3Q 9K546 AA		HK907 (NTA5101)	HK909 (NTA5301)	HK989 (NTA5635)	AHP5065	HK906	N/A	✓	
	Jaguar	C2S 40004									
	PSA	1980.H1 96 489 170 80									
5WS40249 (A2C59511364)	Ford	4H2Q 9K546 AF		HK907 (NTA5101)	HK909 (NTA5301)	HK989 (NTA5635)	AHP5065	HK906	N/A	✓	
	Land Rover	LR006495									
5WS40156-6 (A2C59511601)	Ford	1483820 3M5Q 9F593 FB		HK907 (NTA5101)	HK909 (NTA5301)	HK949 (NTA5624)	AHP5065	HK906	N/A	✓	
	Volvo	312 16 456									
5WS40200 (A2C59511602)	PSA	1980.K5		HK907 (NTA5101)	HK909 (NTA5301)	HK949 (NTA5624)	AHP5065	HK906	N/A	✓	
5WS40441 (A2C59511603)	PSA	1980.K8 96 603 348 80		HK907 (NTA5101)	HK909 (NTA5301)	HK949 (NTA5624)	AHP5065	HK906	N/A	✓	
5WS40516 (A2C59511612)	PSA	1980.L0 96 634 292 80		HK907 (NTA5101)	HK909 (NTA5301)	HK947 (NTA5623)	AHP5065	HK906	N/A	✓	
5WS40539	VW	03L 130 277 B		HK907 (NTA5101)	HK909 (NTA5301)	HK1054 (NTA5679) + HK1011 (NTA5659)	AHP5129	HK906	N/A	✓	
5WS40086 (A2C59511610) 5WS40250 (A2C59511611)	Ford	1355051 1432322	Lynx 1.8 85 to 93kW	HK907 (NTA5101)	HK909 (NTA5301)	HK1025 (NTA5669)	AHP5065	HK906	N/A	✓	
5WS40087 (A2C59511606)	Renault Nissan	8200 842 205 8200 380 253	Clio, Modus, Scenic, Megane Quashqai, Tiida	HK907 (NTA5101)	HK909 (NTA5301)	HK1048 (NTA5677)	AHP5065	HK906	N/A	✓	
1875072C91	Ford		Powerstroke 6.4l	AVM2 & CRI	HK1053 (NTA5107)	HK1017 (NTA5663)	HK1015 (NTA5662)	AHP5130	HK1026	N/A	✓
				IFT-70	N/A	HK1017/C (NTA5663)	N/A	N/A	HK845	N/A	N/A

## **Notas sobre las tablas de aplicación**

Los números de kit HK9xx contienen piezas para cuatro inyectores. Para el CRi-PC de una sola línea, se puede utilizar los mismos números de kit y añadir el sufijo "/C" como, por ejemplo, HK9xx/C; estos kits "/C" contienen las piezas adecuadas para un solo inyector. Con el IFR-50, pueden utilizarse los mismos números de kits de cables pero añadiendo el sufijo "/R", por ejemplo: HK9xx/R. Estos kits "/R" contienen los cables estándar en versiones más cortas adecuadas para el IFR-50.

No son necesarios adaptadores de lengüeta ni bloques de sujeción para IFR-50. Si aparecen números NTA5xxx entre paréntesis debajo del número HK9xx, estos identifican el número de pieza mayor del kit. Su función es la de servir de referencia ya que el kit contiene otros elementos pequeños como juntas tóricas, arandelas o pernos que son necesarios.

N/A = no aplicable                      KNA = kit todavía no anunciado.

El **texto resaltado** se refiere a las aplicaciones añadidas desde la última edición.

## **Tubos flexibles de alta presión**

Las referencias indicadas a continuación son tuberías flexibles de alta presión para soluciones de pruebas con CRi de todas las marcas. Se venden como unidades sueltas; un tubo por línea de inyector:

AHP5065	Tubo flexible HP: 400 x 14 x 12
AHP5066	Tubo flexible HP: 400 x 14 x 14
AHP5129	Tubo flexible HP: 350 x 14 x 12, codo de 90°
AHP5130	Tubo flexible HP: 400 x 14 x 14, codo de 90°

Con el IFR-50, deben utilizarse los tubos flexibles de alta presión de todas las marcas.

## **Accesorio de tubo HP (sólido) recomendado: HK917**

1. El extremo de manguito roscado del tubo debe encajarse en el puerto de raíl.
2. Una el extremo con el raíl y ajuste la posición del manguito como convenga: debe dejarse un hueco de aprox. 1 mm entre el asiento del raíl y el manguito HP para garantizar que el tubo cierre herméticamente sobre la cara cónica (y no sobre el manguito mismo).
3. Apretar la tuerca a mano para posicionar el tubo y luego apretar con 35 kN de par.

Para obtener información sobre los adaptadores para pruebas de fugas, HK952 Delphi, HK953 y HK954 de Bosch véase TB195/16.

Además de éstas, se están desarrollando otras aplicaciones; póngase en contacto con Hartridge™, si desea información actualizada sobre sus productos y aplicaciones.